

Expansion Module for CompactRIO

This document provides information about mounting and grounding your Expansion Module.

Expansion Modules include the cRIO-9803 and the cRIO-9805.

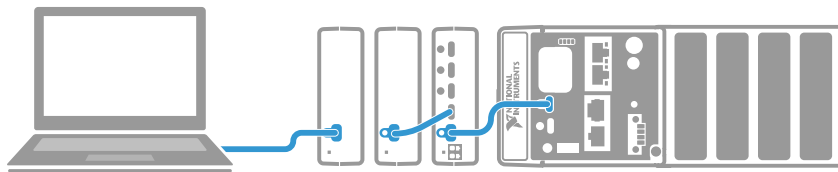

Note Refer to the device Safety, Environmental, and Regulatory Information document, shipped with your device and available on ni.com/manuals, for important safety and environmental specifications necessary when setting up your device.

Contents

Dimensions.....	1
Mounting the Expansion Module with Four Slot Controllers.....	3
Mounting Requirements.....	5
Mounting the System on a Flat Surface (Four Slot Controllers).....	6
Mounting the System on a Panel (Four Slot Controllers).....	8
Mounting the Expansion Module with Eight Slot Controllers.....	11
Mounting Requirements.....	13
Mounting the System on a Flat Surface (Eight Slot Controllers).....	14
Mounting the System on a Panel (Eight Slot Controllers).....	15
Mounting an Expansion Module on a DIN Rail.....	18
Grounding the Expansion Module for CompactRIO	19
NI Services.....	20

Dimensions

The following dimensional drawings apply to all Expansion Modules for CompactRIO. To find detailed dimensional drawings and 3D models for a specific module, visit ni.com/dimensions and search for the module number.

Figure 1. Expansion Module for CompactRIO Front Dimensions

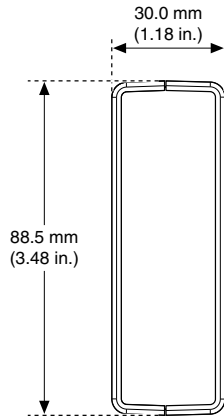

Figure 2. Expansion Module for CompactRIO Rear Dimensions

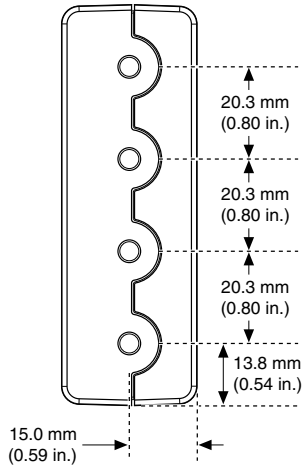
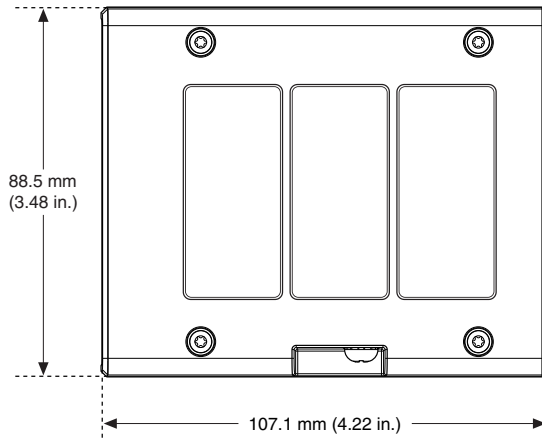

Figure 3. Expansion Module for CompactRIO Side Dimensions



Mounting the Expansion Module with Four Slot Controllers

Observe the following guidelines to obtain the maximum ambient operating temperature and to ensure that your system operates correctly across the full operating temperature range.

Figure 4. System Mounting Configuration

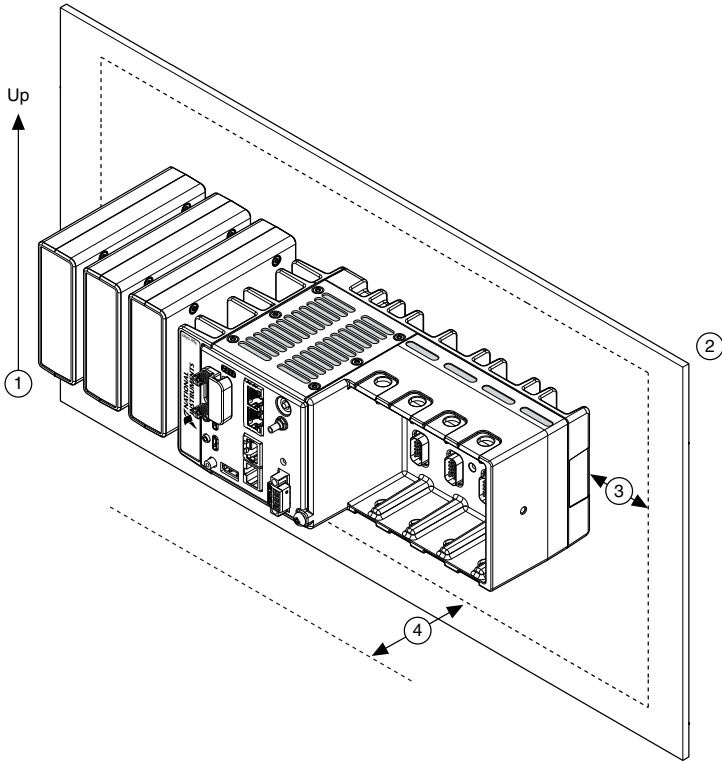

①	Horizontal mounting orientation.
②	Mounting substrate options: <ul style="list-style-type: none">• Mount the system directly to a metallic surface that is at least 1.6 mm (0.062 in.) thick and extends a minimum of 101.6 mm (4 in.) beyond all edges of the device.• Use the NI Panel Mounting Kit to mount the system to a metallic surface that is at least 1.6 mm (0.062 in.) thick and extends a minimum of 101.6 mm (4 in.) beyond all edges of the device.
③	Observe the minimum spacing dimensions in the <i>Mounting Requirements</i> section. Using the NI panel mounting kit ensures minimum spacing dimensions are met.
④	Allow space for cabling clearance according to the <i>Mounting Requirements</i> section.

Mounting Requirements

Figure 5. Minimum Spacing Dimensions

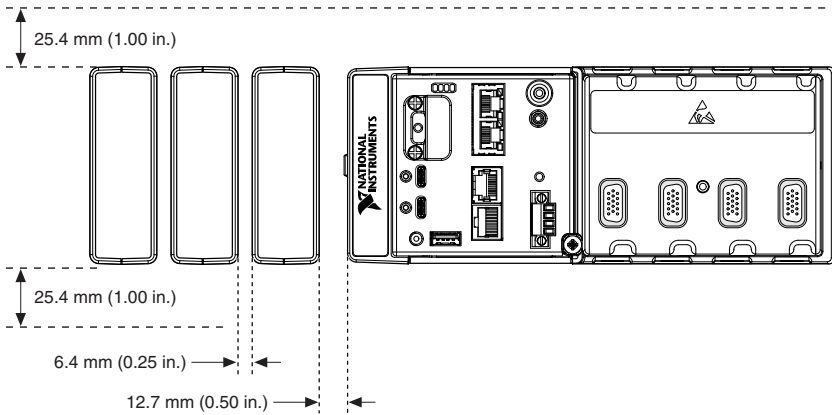
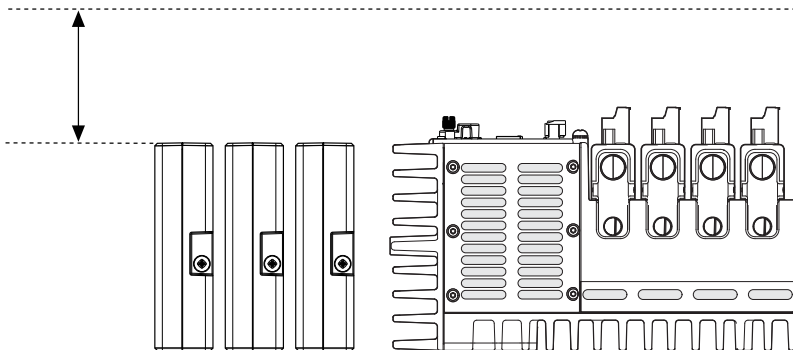
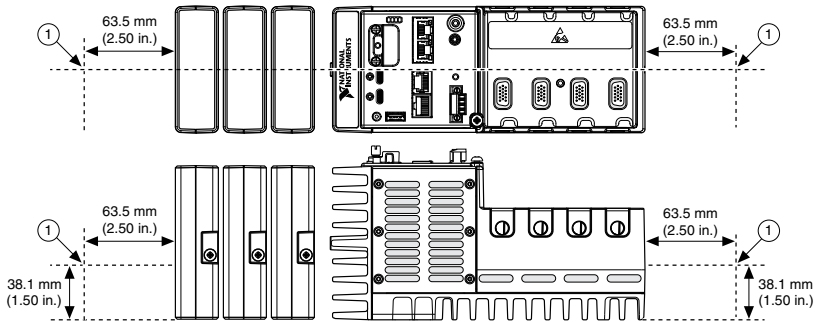

Figure 6. Cabling Clearance



Note The various connector types on Expansion Modules, C Series modules, and the CompactRIO controller may require different cabling clearances. For a complete list of cabling clearances for C Series modules, visit ni.com/info and enter the Info Code `crioconn`.

Figure 7. Ambient Temperature Location



1. Measure the ambient temperature here.

Mounting the System on a Flat Surface (Four Slot Controllers)

For environments with high shock and vibration, NI recommends mounting the system directly on a flat, rigid surface using the mounting holes in the Expansion Module and the CompactRIO controller.

What to Use

- Expansion Module for CompactRIO
- CompactRIO controller
- M4 x 0.7 thread screw (up to x10), user-provided

What to Do

Complete the following steps to mount the system directly on a flat surface.

Figure 8. Mounting the System on a Flat Surface

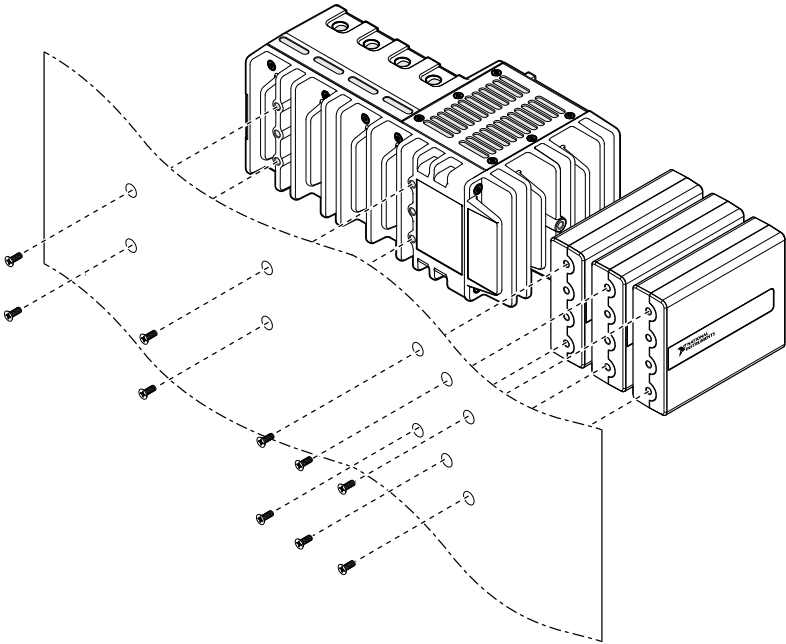

1. Prepare the surface for mounting the system using the *Surface Mounting Dimensions*.
2. Align the module(s) and the controller on the surface.
3. Fasten the module(s) and the controller to the surface using M4 screws appropriate for the surface.
 - Screws must not exceed 8 mm of insertion into the module(s) and the controller.
 - Tighten the screws to a maximum torque of 1.3 N · m (11.5 lb · in.).

Surface Mounting Dimensions (Four Slot Controllers)

Figure 9. Expansion Module for CompactRIO Surface Mounting Dimensions

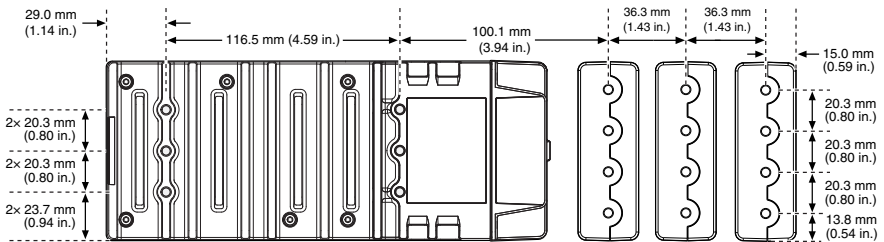

Mounting the System on a Panel (Four Slot Controllers)

What to Use

To mount one module:

- Expansion Module for CompactRIO
- CompactRIO controller
- Screwdriver, Phillips #2
- NI panel mounting kit, 786795-01
 - Panel mounting plate
 - M4 x 10 mm screw (x6)

(Optional) To mount each additional module:

- NI panel mounting nesting bracket kit, 787135-01
 - Nesting bracket
 - M4 x 10 mm screw (x4)

To mount the panel to a surface:

- Screwdriver
- Screws (x3), M5 (#10) maximum, user-provided, appropriate for surface

What to Do

Complete the following steps to mount the system on a panel.

Figure 10. Mounting One Module

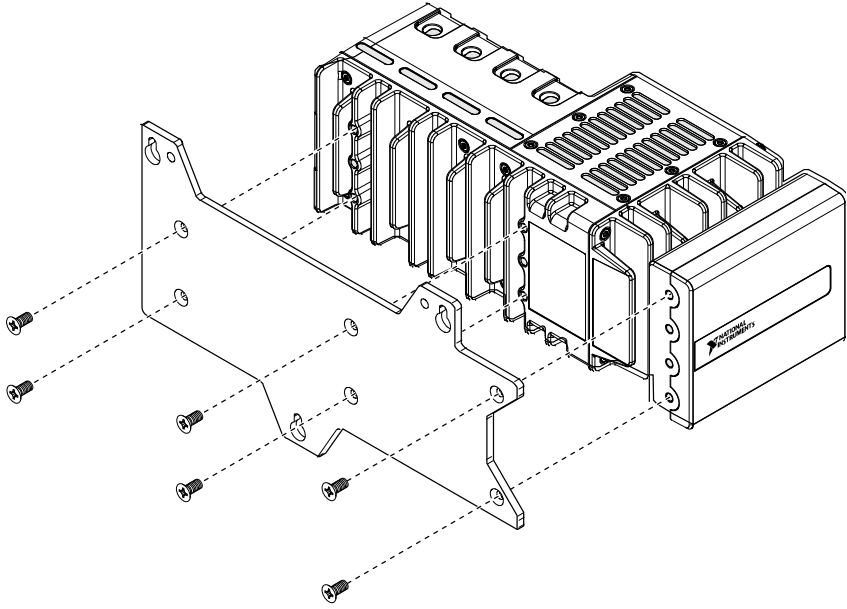
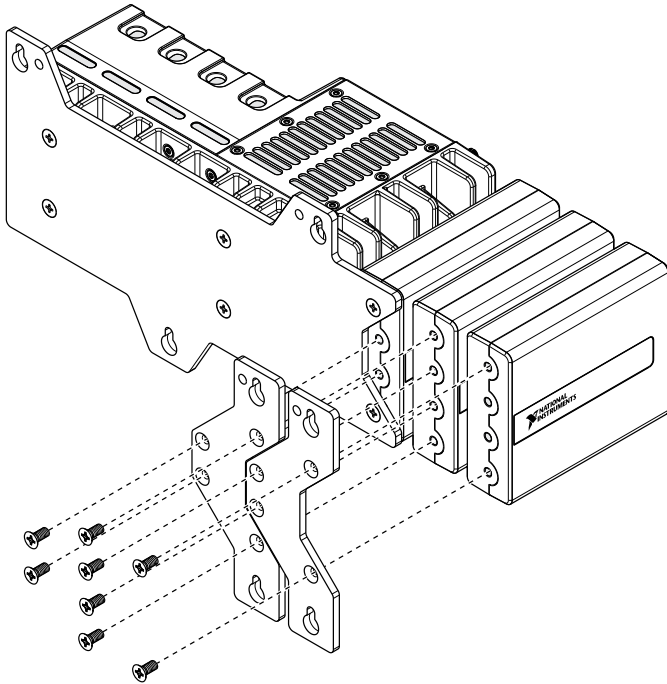

Figure 11. Mounting Multiple Modules (Optional)



1. Fasten the panel mounting plate to the controller and the first expansion module.



Note You must use the screws provided with the NI panel mounting kit because they are the correct depth and thread for the panel mounting plate.



Note Tighten all screws to a maximum torque of 1.3 N · m (11.5 lb · in.).

2. (Optional) Mount one or two additional modules to the system using nesting brackets.
 - a) Fasten the nesting bracket to the adjacent, mounted module.
 - b) Align and fasten the next module to the nesting bracket.
3. Fasten the panel mounting plate to the surface using screws that are appropriate for the surface.

Panel Mounting Dimensions (Four Slot Controller)

Figure 12. Panel Mounting Dimensions, One Module

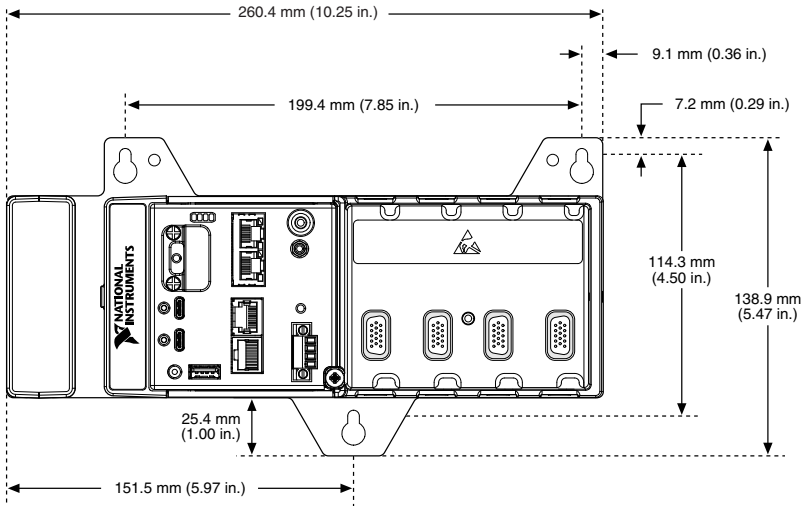
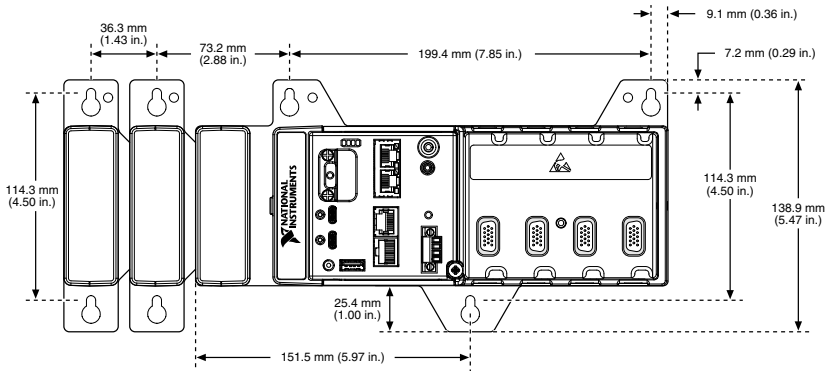

Figure 13. Panel Mounting Dimensions, Multiple Modules



Mounting the Expansion Module with Eight Slot Controllers

Observe the following guidelines to obtain the maximum ambient operating temperature and to ensure that your system operates correctly across the full operating temperature range.

Figure 14. System Mounting Configuration

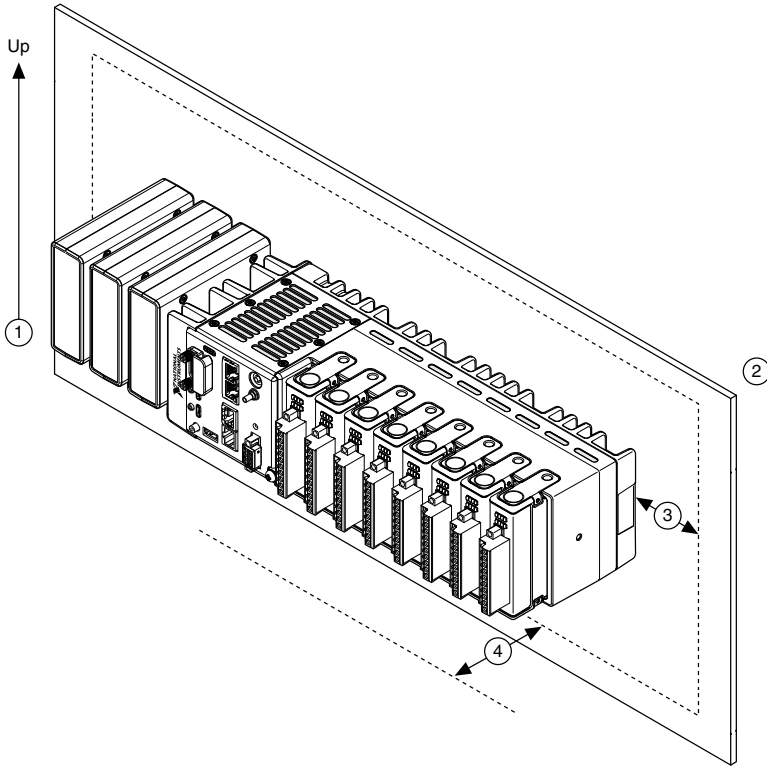

①	Horizontal mounting orientation.
②	Mounting substrate options: <ul style="list-style-type: none">• Mount the system directly to a metallic surface that is at least 1.6 mm (0.062 in.) thick and extends a minimum of 101.6 mm (4 in.) beyond all edges of the device.• Use the NI Panel Mounting Kit to mount the system to a metallic surface that is at least 1.6 mm (0.062 in.) thick and extends a minimum of 101.6 mm (4 in.) beyond all edges of the device.
③	Observe the minimum spacing dimensions in the <i>Mounting Requirements</i> section. Using the NI panel mounting kit ensures minimum spacing dimensions are met.
④	Allow space for cabling clearance according to the <i>Mounting Requirements</i> section.

Mounting Requirements

Figure 15. Minimum Spacing Dimensions

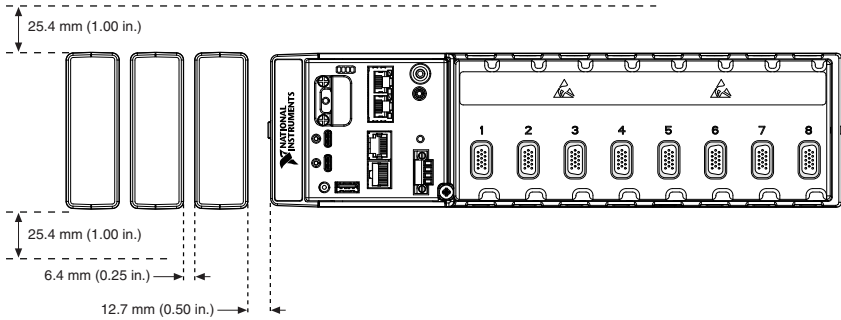
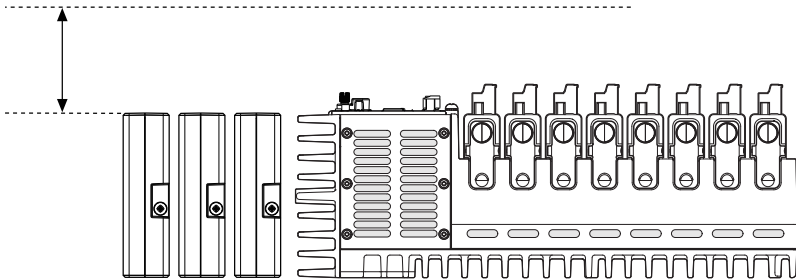
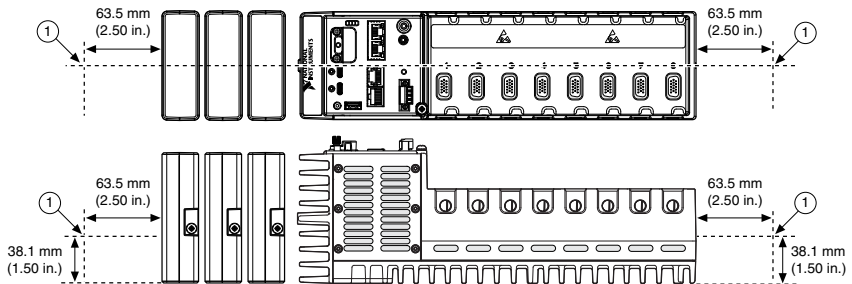

Figure 16. Cabling Clearance



Note The various connector types on Expansion Modules, C Series modules, and the CompactRIO controller may require different cabling clearances. For a complete list of cabling clearances for C Series modules, visit ni.com/info and enter the Info Code `crioconn`.

Figure 17. Ambient Temperature Location



1. Measure the ambient temperature here.

Mounting the System on a Flat Surface (Eight Slot Controllers)

For environments with high shock and vibration, NI recommends mounting the system directly on a flat, rigid surface using the mounting holes in the Expansion Module and the CompactRIO controller.

What to Use

- Expansion Module for CompactRIO
- CompactRIO controller
- M4 x 0.7 thread screw (up to x12), user-provided

What to Do

Complete the following steps to mount the system directly on a flat surface.

Figure 18. Mounting the System on a Flat Surface

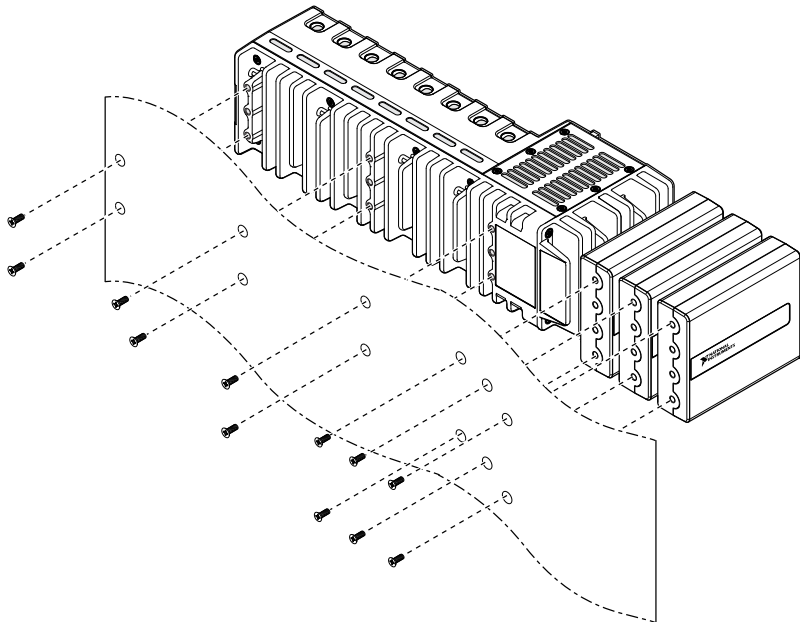

1. Prepare the surface for mounting the system using the *Surface Mounting Dimensions*.
2. Align the module(s) and the controller on the surface.

3. Fasten the module(s) and the controller to the surface using M4 screws appropriate for the surface.
 - Screws must not exceed 8 mm of insertion into the module(s) and the controller.
 - Tighten the screws to a maximum torque of 1.3 N · m (11.5 lb · in.).

Surface Mounting Dimensions (Eight Slot Controllers)

Figure 19. Expansion Module for CompactRIO Surface Mounting Dimensions

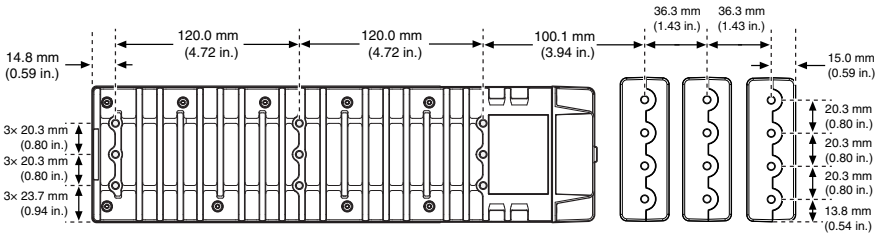

Mounting the System on a Panel (Eight Slot Controllers)

What to Use

To mount one module:

- Expansion Module for CompactRIO
- CompactRIO controller
- Screwdriver, Phillips #2
- NI panel mounting kit, 786796-01
 - Panel mounting plate
 - M4 x 10 mm screw (x8)

(Optional) To mount each additional module:

- NI panel mounting nesting bracket kit, 787135-01
 - Nesting bracket
 - M4 x 10 mm screw (x4)

To mount the panel to a surface:

- Screwdriver
- Screws (x5), M5 (#10) maximum, user-provided, appropriate for surface

What to Do

Complete the following steps to mount the system on a panel.

Figure 20. Mounting One Module

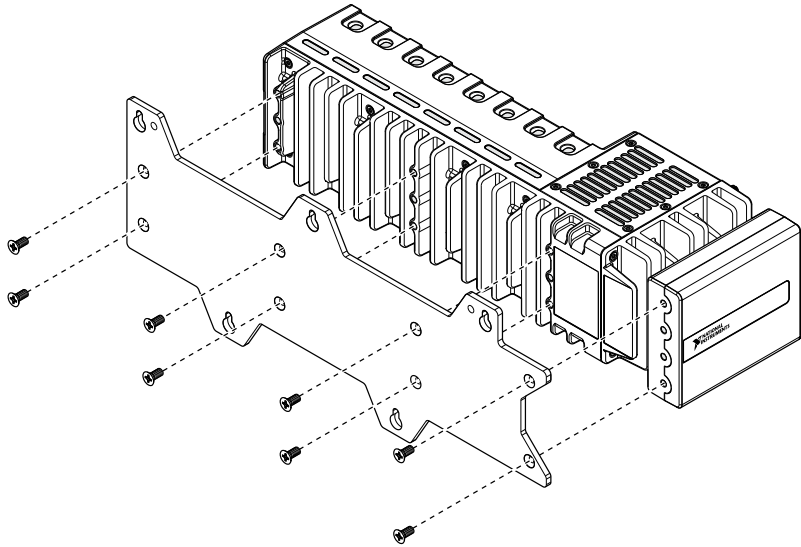
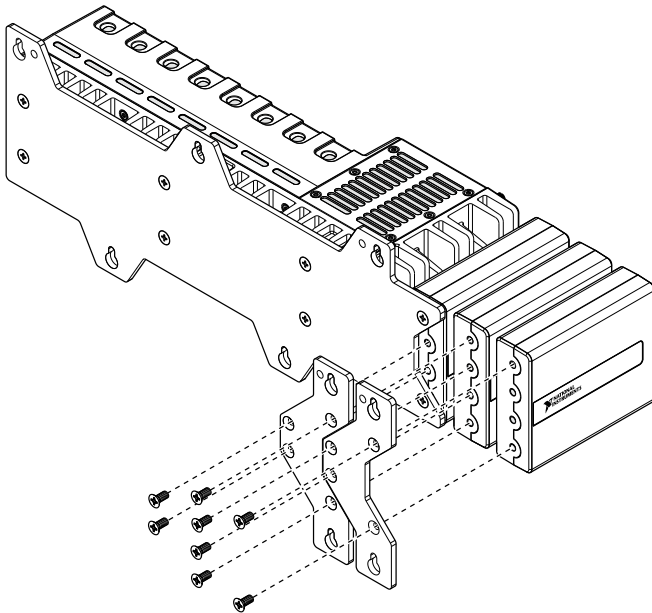

Figure 21. Mounting Multiple Modules (Optional)



1. Fasten the panel mounting plate to the controller and the first expansion module.



Note You must use the screws provided with the NI panel mounting kit because they are the correct depth and thread for the panel mounting plate.



Note Tighten all screws to a maximum torque of $1.3 \text{ N} \cdot \text{m}$ ($11.5 \text{ lb} \cdot \text{in.}$).

2. (Optional) Mount one or two additional modules to the system using nesting brackets.
 - a) Fasten the nesting bracket to the adjacent, mounted module.
 - b) Align and fasten the next module to the nesting bracket.
3. Fasten the panel mounting plate to the surface using screws that are appropriate for the surface.

Panel Mounting Dimensions (Eight Slot Controller)

Figure 22. Panel Mounting Dimensions, One Module

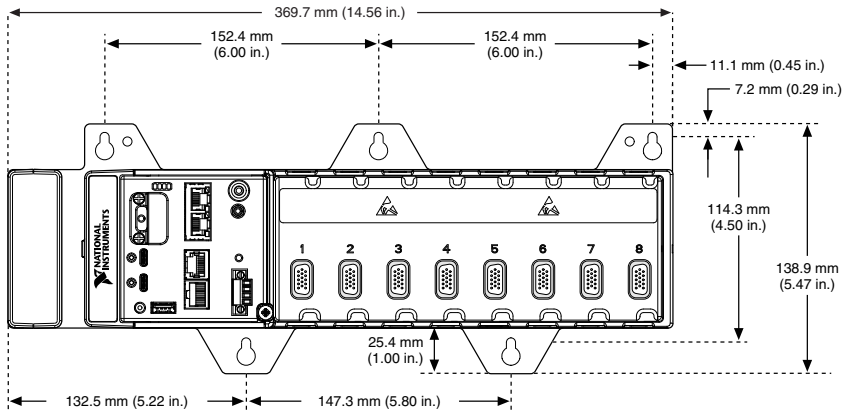
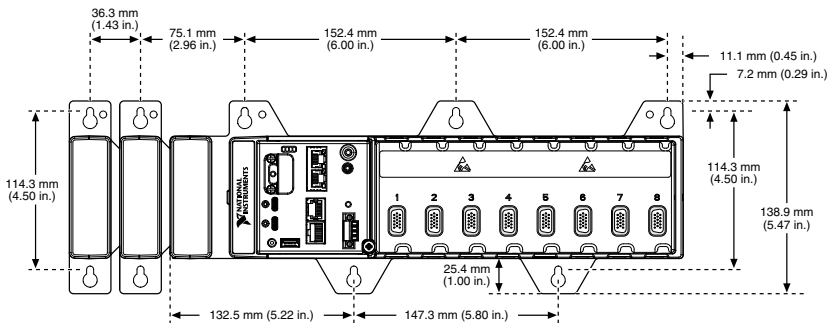

Figure 23. Panel Mounting Dimensions, Multiple Modules



Mounting an Expansion Module on a DIN Rail

What to Use

- Expansion Module for CompactRIO
- DIN rail mounting kit, 786797-01
 - Standard DIN rail clip
 - M4 screw (x2)

What to do

Complete the following steps to mount the Expansion Module for CompactRIO on a DIN Rail.

Figure 24. Mounting the Module on a DIN Rail

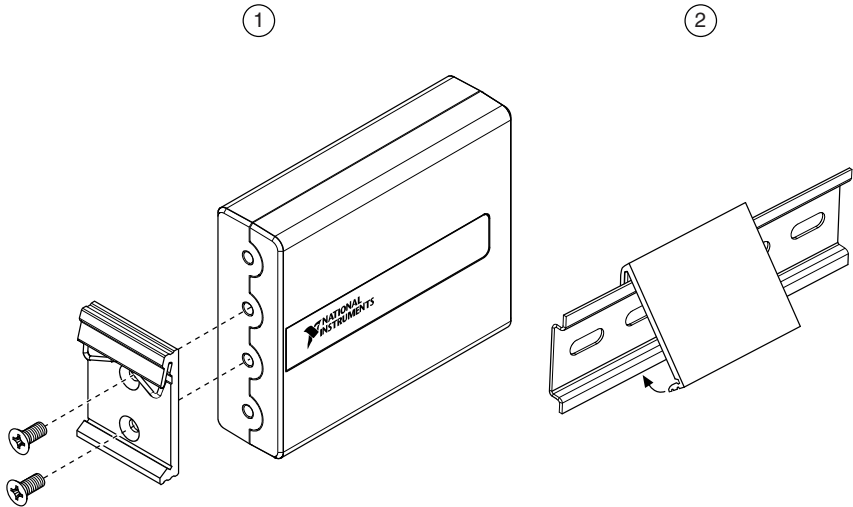

1. Attach the DIN rail clip to the back of the module. Tighten the screws to a maximum torque of $1.3 \text{ N} \cdot \text{m}$ ($11.5 \text{ lb} \cdot \text{in.}$).



Note You must use the screws provided with the NI DIN rail mounting kit because they are the correct depth and thread for the DIN rail clip.

2. Snap the DIN rail clip onto the DIN rail.
 - Observe the spacing dimensions in the *Mounting Requirements* section.

Grounding the Expansion Module for CompactRIO

You must connect the Expansion Module for CompactRIO grounding terminal to the grounding electrode system of the facility.



Note For more information about ground connections, visit ni.com/r/emcground.

What to Use

- Right angle ring lug
- Wire, 1.3 mm² (16 AWG) or larger
- Screwdriver, Phillips #2

What to Do

Complete the following steps to ground the Expansion Module for CompactRIO.

Figure 25. Installing the Ground Wire

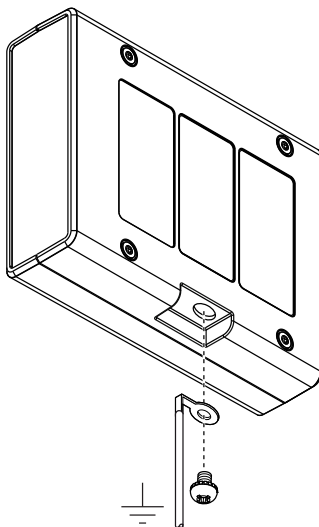

1. Attach the ring lug to the wire.



Note NI recommends using a right angle ring lug to ensure sufficient cabling clearance for the ground wire. If your system uses a single module, a standard ring lug may be sufficient for cabling clearance.

2. Remove the grounding screw from the grounding terminal on the bottom of the module.
3. Fasten the ring lug to the grounding terminal.

4. Tighten the grounding screw to 0.5 N · m (4.4 lb · in.) of torque.
5. Attach the other end of the wire to the chassis safety ground using a method that is appropriate for your application.

NI Services

Visit ni.com/support to find support resources including documentation, downloads, and troubleshooting and application development self-help such as tutorials and examples.

Visit ni.com/services to learn about NI service offerings such as calibration options, repair, and replacement.

Visit ni.com/register to register your NI product. Product registration facilitates technical support and ensures that you receive important information updates from NI.

NI corporate headquarters is located at 11500 N Mopac Expwy, Austin, TX, 78759-3504, USA.

Information is subject to change without notice. Refer to the *NI Trademarks and Logo Guidelines* at ni.com/trademarks for information on NI trademarks. Other product and company names mentioned herein are trademarks or trade names of their respective companies. For patents covering NI products/technology, refer to the appropriate location: **Help»Patents** in your software, the `patents.txt` file on your media, or the *National Instruments Patent Notice* at ni.com/patents. You can find information about end-user license agreements (EULAs) and third-party legal notices in the `readme` file for your NI product. Refer to the *Export Compliance Information* at ni.com/legal/export-compliance for the NI global trade compliance policy and how to obtain relevant HTS codes, ECCNs, and other import/export data. NI MAKES NO EXPRESS OR IMPLIED WARRANTIES AS TO THE ACCURACY OF THE INFORMATION CONTAINED HEREIN AND SHALL NOT BE LIABLE FOR ANY ERRORS. U.S. Government Customers: The data contained in this manual was developed at private expense and is subject to the applicable limited rights and restricted data rights as set forth in FAR 52.227-14, DFAR 252.227-7014, and DFAR 252.227-7015.

© 2018—2020 National Instruments Corporation. All rights reserved.

377090D-03 November 11, 2020